

Product Features:

- Low Jitter, Non-PLL Based Output
- CMOS Output
- Wide Range of Supply Voltage (+1.8V to +3.3 V)
- Stand-by Function on Pin 1
- RoHS Compliant
- Compatible with Leadfree Processing

Applications:

- Fibre Channel
- Server & Storage
- Sonet / SDH
- 802.11 / Wifi
- T1/E1, T3/E3

Frequency	1.000000 MHz to 80.000000 MHz
Output Level CMOS	Logic "0" = 0.4 V max Logic "1" = Vcc - 0.4 V min
Duty Cycle	See Duty Cycle Table in Part Number Guide
Rise / Fall Time	4.5 nSec max (10% to 90% of waveform)
Output Load	15pF max
Frequency Stability	See Frequency Stability Table in Part Number Guide (Note 1)
Start-up time	2.0 mSec max with Vcc = +3.30 VDC 5.0 mSec max with Vcc = +1.80 VDC
Stand By Terminal Function (Pin 1)	0.7 Vcc min = Output enable 0.3 Vcc max = Oscillation stop and High impedance output
Supply Voltage (Vcc)	See Input Voltage Table in Part Number Guide (Tolerance = ±10%)
Current During Standby During Operation	10 µA max 2.5 typ., 3.5 mA max (1.8 V, 15 pF load @ 50.000MHz) 3.5 typ., 5.0 mA max (1.8 V, 15 pF load @ 80.000MHz) 4.2 typ., 6.0 mA max (3.3 V, 15 pF load @ 50.000MHz) 6.0 typ., 8.5 mA max (3.3 V, 15 pF load @ 80.000MHz)
Aging	± 3.0 ppm max @ +25°C First Year
Temperature Range Operating Storage	See Operating Temperature Table in Part Number Guide -40°C to +105°C
Random Jitter (RJ)	2.9 pSec typ
Total Jitter (TJ)	40.0 pSec typ TJ = n x RJ where n ≈ 14.1, BER = 10 ⁻¹²
Phase Jitter	1.0 pSec max Offset frequency = 12 kHz to 5.000MHZ

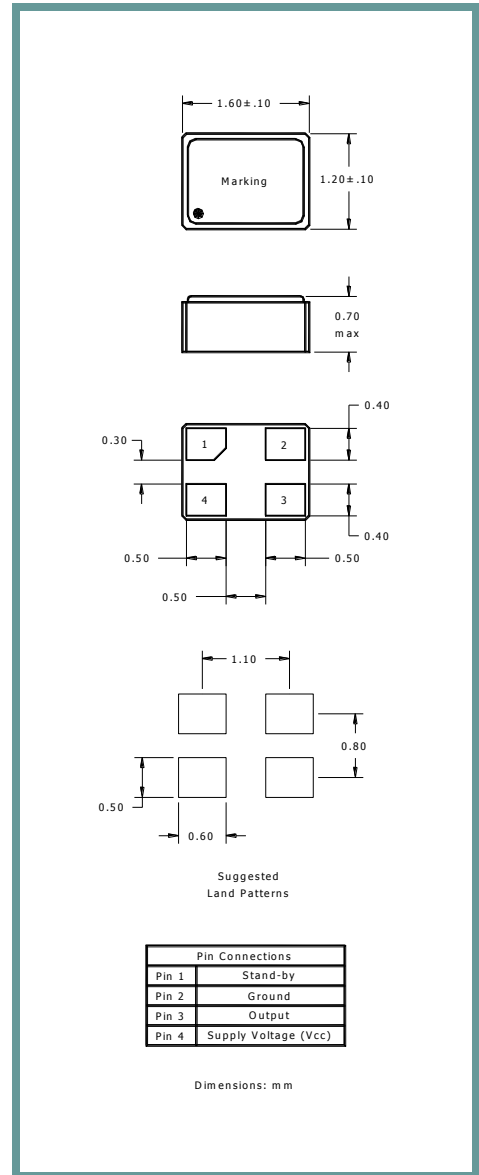

Notes:

1. Includes room temperature tolerance and stability over operating temperature.
2. A 0.01 µF bypass capacitor is recommended between Vcc (Pin 4) and GND (Pin 2) to minimize power supply noise.

Part Number Guide:		Sample Part Number: ISM16-3153A-20.0000				
Package	Input Voltage	Operating Temperature	Duty Cycle (Symmetry)	Output	Stability (in ppm)	Frequency
ISM16	1 = +1.8V	1 = 0°C to +70°C	5 = 45/55 max	3 = 15 pF	A = ±25*	-20.0000
	3 = +3.3V	2 = -40°C to +85°C	6 = 40/60 max		B = ±50	
	6 = +2.5V	3 = -20°C to +70°C			C = ±100	
		5 = -30°C to +85°C			F = ±20*	
					G = ±30	

*Not available for all temperature ranges

Pb Free Solder Reflow Profile:

Typical Application:

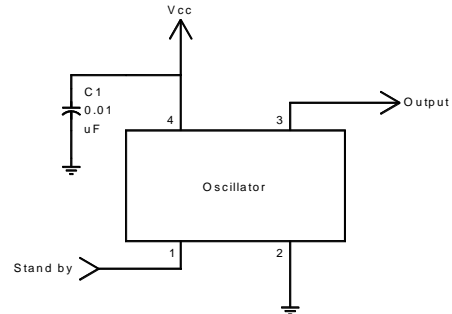
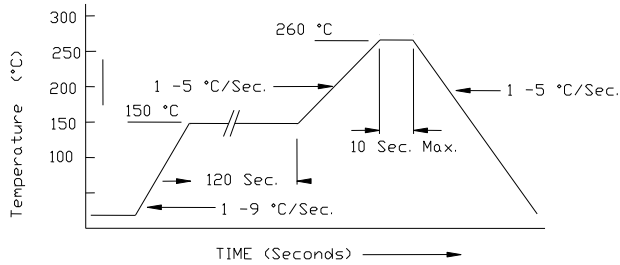

Units are backward compatible with 240°C reflow process.

Package Information:

MSL = N.A. (package does not contain plastic; storage life is unlimited under normal room conditions).
Termination = e4 (Au over Ni over W base metallization).

Tape and Reel Information:

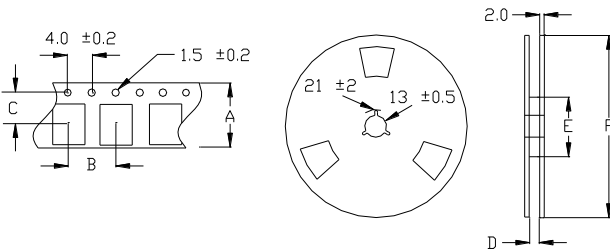

Quantity per Reel	3000
A	8.0 ±0.2
B	4.0 ±0.1
C	3.5 ±0.05
D	9.0 ±0.3
E	60 / 80
F	180 / 250

Environmental Specifications:

Thermal Shock	MIL-STD-883, Method 1011, Condition A
Moisture Resistance	MIL-STD-883, Method 1004
Mechanical Shock	MIL-STD-883, Method 2002, Condition B
Mechanical Vibration	MIL-STD-883, Method 2007, Condition A
Resistance to Soldering Heat	J-STD-020C, Table 5-2 Pb-free devices (except 2 cycles max)
Hazardous Substance	Pb-Free / RoHS / Green Compliant
Solderability	JESD22-B102-D Method 2 (Preconditioning E)
Terminal Strength	MIL-STD-883, Method 2004, Test Condition D
Gross Leak	MIL-STD-883, Method 1014, Condition C
Fine Leak	MIL-STD-883, Method 1014, Condition A2, R1=2x10 ⁻⁸ atm cc/s
Solvent Resistance	MIL-STD-202, Method 215

Marking:

Line 1: 1 - Date Code (yww)
Line 2: Frequency

PROPRIETARY AND CONFIDENTIAL

THIS DOCUMENT CONTAINS PROPRIETARY INFORMATION, AND SUCH INFORMATION MAY NOT BE DISCLOSED TO OTHERS FOR ANY PURPOSE NOR USED FOR MANUFACTURING PURPOSES WITHOUT WRITTEN PERMISSION FROM ILSI America.