

2.0 mm x 1.6 mm Ceramic Package SMD Oscillator, CMOS

ISM36 Series

Product Features:

Very Low Current Consumption
CMOS Logic Levels
Compatible with Leadfree Processing
Small Footprint Package
AT Cut Temperature Stability Characteristics

Applications:

Real Time Clocks
Metering
Industrial Control
Time Reference
System Clock

Frequency	32.768 kHz
Output Level CMOS	'0' = 0.1 V _{CC} Max., '1' = 0.9 V _{CC} Min.
Duty Cycle	50% ±5%
Rise / Fall Time	50 nSec Max. 1.8V (20% to 80% V _{CC} Levels) 40 nSec Max. 2.5V (20% to 80% V _{CC} Levels) 30 nSec Max. 3.3V (20% to 80% V _{CC} Levels)
Output Load	15pF Max
Frequency Tolerance (at +25°C)	See Part Number Guide Below
Frequency Stability	See Part Number Guide Below
Enable / Disable Time	200 nSec Max
Start Up Time	7.0 mSec Max. (V _{CC} = 3.3V) 10.0 mSec Max. (V _{CC} = 1.8V)
Supply Voltage	See Input Voltage Table, tolerance ±10%
Current Operating	40 µA Max. (F=32.768kHz, V _{CC} = 3.3V, 15 pF load)
Current Standby	3 µA Max
Stand-by Function	Output Enable (High) = 0.7 V _{CC} Min, Output Disable (Low/High Impedance) = 0.3 V _{CC} Max.
Operating	See Operating Temperature Table in Part Number Guide
Storage	-40° C to +105° C Standard

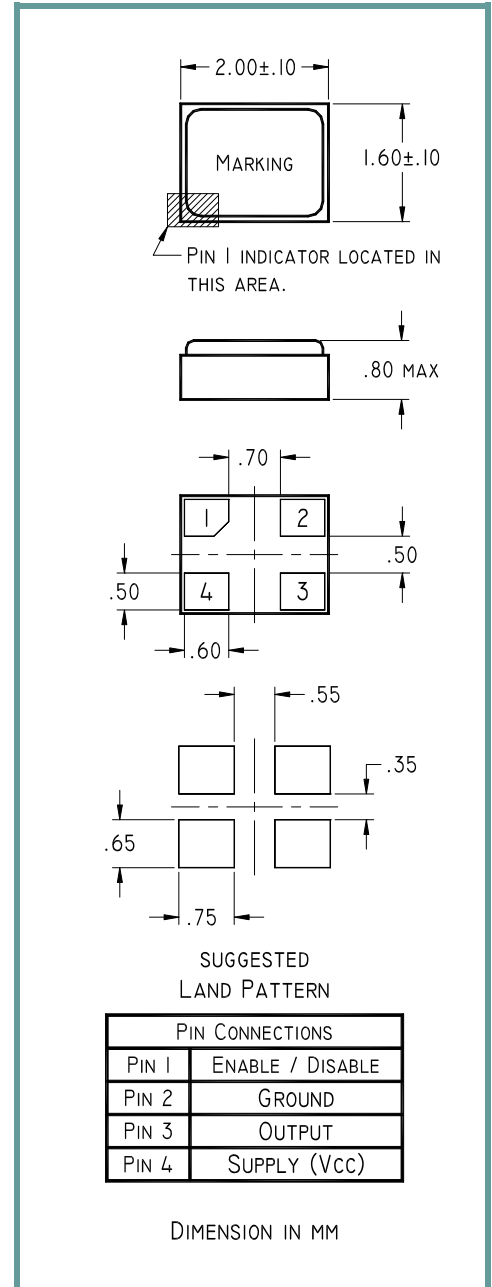

Part Number Guide		Sample Part Number:		ISM36 -32ZBH – 32.768 kHz		
Package	Input Voltage	Operating Temperature	Frequency Tolerance 25°C (in ppm)	Stability (in ppm)	Enable / Disable	Frequency
ISM36 -	3 = 3.3 V	1 = 0° C to +70° C	E = ±10	E = ±10*	H = Stand-by	- 32.768 kHz
	6 = 2.5 V	3 = -20° C to +70° C	D = ±15	D = ±15		
	1 = 1.8 V	5 = -30° C to +85° C	F = ±20	F = ±20		
		2 = -40° C to +85° C	Z = ±30	Z = ±30		
			B = ±50	B = ±50		

NOTE: A 0.01 µF bypass capacitor is recommended between V_{DD} (pin 4) and GND (pin 2) to minimize power supply noise. * Not available at all operating temperature options.

2.0 mm x 1.6 mm Ceramic Package SMD Oscillator, CMOS

ISM36 Series

Pb Free Solder Reflow Profile

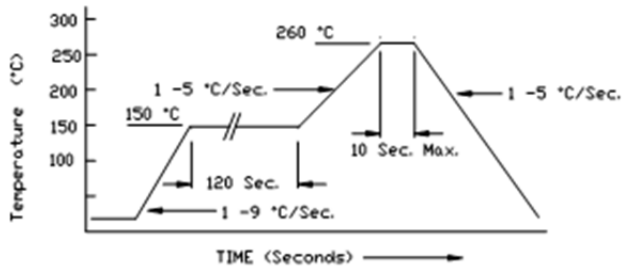

Typical Application:

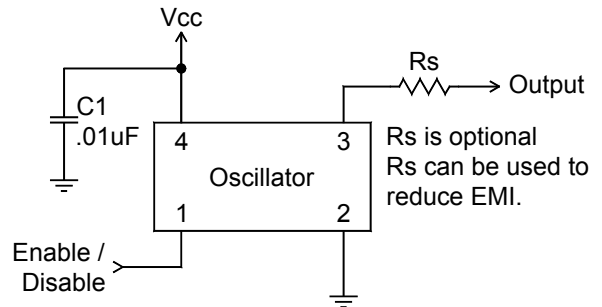

Units are backward compatible with 240C reflow processes

Package Information:

MSL = N.A. (package does not contain plastic, storage life is unlimited under normal room conditions).
Termination = e4 (Au over Ni over W base metallization).

Tape and Reel Information:

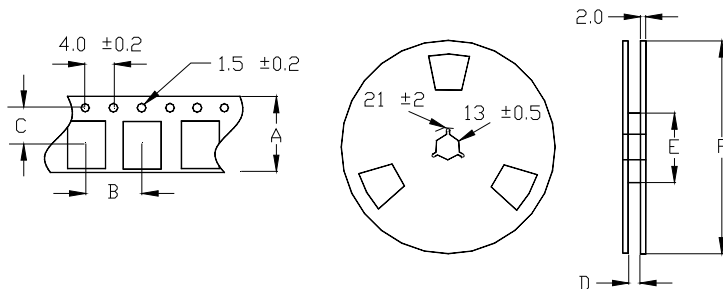

Quantity per Reel	3000
A	8.0+/- .3
B	4.0 +/- .2
C	3.5 +/- .2
D	16.5 +/- .2
E	50 / 60 / 80
F	180

Environmental Specifications

Thermal Shock	MIL-STD-883, Method 1011, Condition A
Moisture Resistance	MIL-STD-883, Method 1004
Mechanical Shock	MIL-STD-883, Method 2002, Condition B
Mechanical Vibration	MIL-STD-883, Method 2007, Condition A
Resistance to Soldering Heat	J-STD-020C, Table 5-2 Pb-free devices (except 2 cycles max)
Hazardous Substance	Pb-Free / RoHS / Green Compliant
Solderability	JESD22-B102-D Method 2 (Preconditioning E)
Gross Leak	MIL-STD-883, Method 1014, Condition C
Fine Leak	MIL-STD-883, Method 1014, Condition A2, R1=2x10 ⁻⁸ atm cc/s
Solvent Resistance	MIL-STD-202, Method 215

Marking

Line 1: I-Date Code (YWW)

Line 2: Frequency