



3.2 mm x 5.0 mm Ceramic Package SMD  
 VCXO, LVCMOS / LVPECL / LVDS

I640 - Series

**Product Features**

Small Surface Mount Package  
 Fast Sample Delivery  
 Frequencies to 1500 MHz  
 Pb Free/ RoHS Compliant  
 Leadfree Processing

**Applications**

xDSL  
 Broadcast video  
 Wireless Base Stations  
 Sonet /SDH  
 WiMAX/WLAN  
 Server and Storage  
 Ethernet/LAN/WAN  
 Optical modules  
 Clock and data recovery  
 FPGA/ASIC  
 Backplanes  
 GPON

<b>Frequency</b> LVCMOS LVPECL LVDS	10 MHz to 250 MHz 10 MHz to 1500 MHz 10 MHz to 1500 MHz
<b>Output Level</b> LVCMOS LVPECL LVDS	VOH=90% VDD min., VOL=10 % VDD max. VOH=VDD-1.03V max. (Nom. Load), VOL=VDD-1.6V max. (Nom. Load) VOD=(Diff. Output) 350mV Typ.
<b>Duty Cycle</b> LVCMOS LVPECL LVDS	50% ±5% @ 50%VDD 50% ±5% @ 50%* 50% ±5% @ 50%*
<b>Rise / Fall Time</b> LVCMOS LVPECL LVDS	3.0 ns max. (90%/10%)* 0.6 ns max. (80%/20%)* 0.6 ns max. (80%/20%)*
<b>Output Load</b> LVCMOS LVPECL LVDS	15pF 50 Ω to VDD - 2.0 VDC RL=100 Ω/CL=10pF
<b>Frequency Stability</b>	See Table Below
<b>Supply Voltage</b>	3.3 VDC ± 10%, 2.5VDC ± 5%
<b>Current</b>	LVCMOS = 45 mA max., LVPECL = 65 mA max., LVDS = 35 mA max.
<b>Linearity</b>	10% max.
<b>Pullability</b>	See Table Below
<b>Control Voltage</b>	1.65 VDC ± 1.65 VDC @ 3.3V 1.25 VDC ± 1.25 VDC @ 2.5V
<b>Input Impedance</b>	50K Ω min.
<b>Phase Jitter (RMS) At 12kHz to 20 MHz</b>	0.9 ps typical
<b>Operating Temp. Range</b>	See Table Below
<b>Storage</b>	-40° C to +100° C

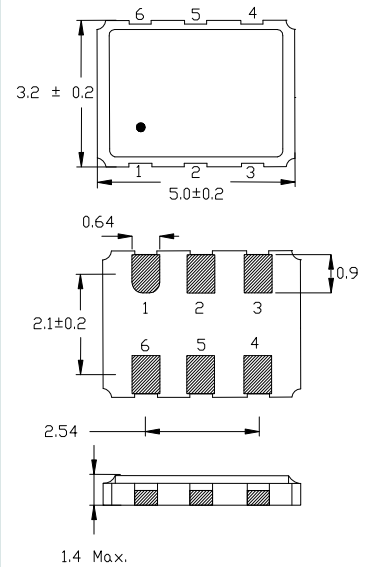

Recommended Pad Layout

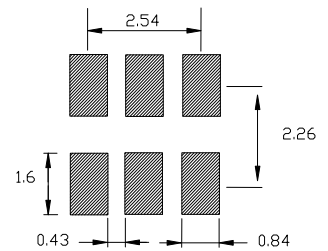

Pin	Connection
1	Voltage Control
2	Enable/Disable or N/C
3	GND
4	Output
5	Output or N/C
6	V <sub>DD</sub>

Dimension Units: mm

Part Number Guide		Sample Part Number: I640-31AB9H2-155.520						
Package	Input Voltage	Operating Temperature	Stability (in ppm)	Pullability	Output	Enable / Disable (Pin 2)	Complimentary Ouput (Pin 5) **	Frequency
I640	3 = 3.3V	1 = 0° C to +70° C	F = ±20	B = ± 50	3 = LVCMOS	H = Enable	1 = N.C.	-155.520 MHz
	6 = 2.5V	3 = -20° C to +70° C	A = ±25	C = ±100	8 = LVDS	O = N/C	2 = Output	
		2 = -40° C to +85° C	B = ±50		9 = LVPECL			

NOTE: A 0.01 μF bypass capacitor is recommended between V<sub>DD</sub> (pin 6) and GND (pin 3) to minimize power supply noise. \* Measured as percent of waveform. \*\* Available on LVDS and LVPECL output only.



3.2 mm x 5.0 mm Ceramic Package SMD  
 VCXO, LVCMOS / LVPECL / LVDS

I640 - Series

**SSB Phase Noise (typ.)**

Offset	77.76 MHz	155.52 MHz	622.08 MHz
10Hz	-75 dBc/Hz	-62 dBc/Hz	-47 dBc/Hz
100Hz	-105 dBc/Hz	-101 dBc/Hz	-79 dBc/Hz
1kHz	-117 dBc/Hz	-112 dBc/Hz	-100 dBc/Hz
10kHz	-123 dBc/Hz	-115 dBc/Hz	-104 dBc/Hz
100kHz	-125 dBc/Hz	-118 dBc/Hz	-106 dBc/Hz

**Typical Application:**

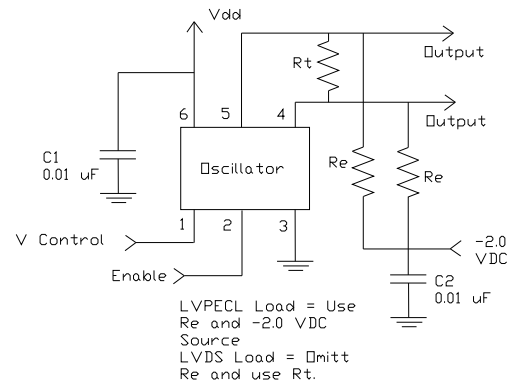
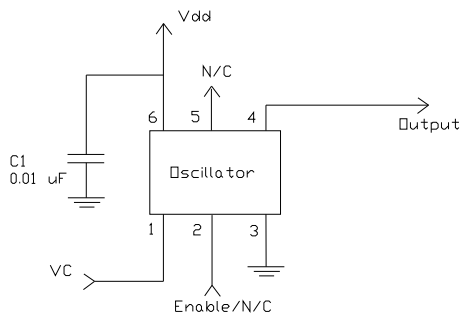

**Pb Free Solder Reflow Profile:**

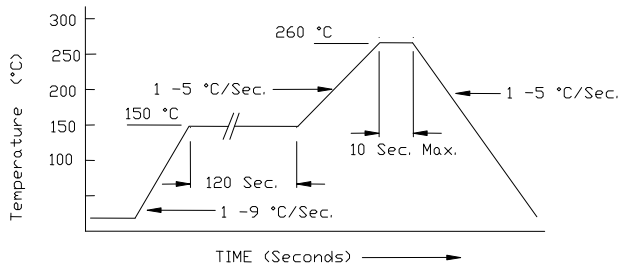

\*Units are backward compatible with 240C reflow processes

**Package Information:**

MSL = N.A. (package does not contain plastic, storage life is unlimited under normal room conditions).  
 Termination = e4 (Au over Ni over W base metalization).



3.2 mm x 5.0 mm Ceramic Package SMD  
 VCXO, LVCMOS / LVPECL / LVDS

I640 - Series

**Tape and Reel Information:**

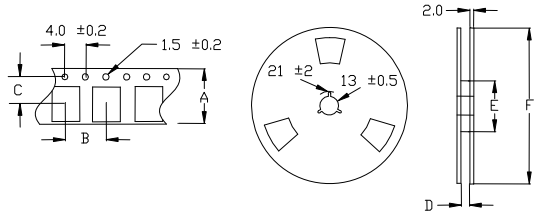

Quantity per Reel	1000
A	16 +/- .3
B	8 +/- .2
C	7.5 +/- .2
D	17.5 +/- .1
E	50 / 60 / 80
F	180 / 250

**Environmental Specifications**

Thermal Shock	MIL-STD-883, Method 1011, Condition A
Moisture Resistance	MIL-STD-883, Method 1004
Mechanical Shock	MIL-STD-883, Method 2002, Condition B
Mechanical Vibration	MIL-STD-883, Method 2007, Condition A
Resistance to Soldering Heat	J-STD-020C, Table 5-2 Pb-free devices (except 2 cycles max)
Hazardous Substance	Pb-Free / RoHS / Green Compliant
Solderability	JESD22-B102-D Method 2 (Preconditioning E)
Terminal Strength	MIL-STD-883, Method 2004, Test Condition D
Gross Leak	MIL-STD-883, Method 1014, Condition C
Fine Leak	MIL-STD-883, Method 1014, Condition A2, R1=2x10 <sup>-8</sup> atm cc/s
Solvent Resistance	MIL-STD-202, Method 215

**Marking**

Line 1: ILSI and Date Code (YWW)  
 Line 2: Frequency