



2 Lead Metal Package, 3.2 mm x 8 mm



UM1 / UM4 / UM5 Series

Product Features:

- Low Cost
- RoHs Compliant
- Compatible with Leadfree Processing

Applications:

- Fibre Channel
- Server & Storage
- Sonet /SDH
- 802.11 / Wifi
- T1/E1, T3/E3
- System Clock

Frequency	7 MHz to 160.000 MHz
ESR (Equivalent Series Resistance)	
7.0 MHz – 9.9 MHz	100 Ω Max.
10.0 MHz – 14.9 MHz	60 Ω Max.
15 MHz – 29.9 MHz	30 Ω Max.
30 MHz – 36 MHz	20 Ω Max.
30 MHz – 49.9 MHz (3 rd O.T.)	70 Ω Max.
50 MHz – 100 MHz (3 rd O.T.)	50 Ω Max.
75 MHz – 160 MHz (5 th O.T.)	100 Ω Max.
Shunt Capacitance (C0)	7 pF Max.
Frequency Tolerance @ 25° C	±30 ppm Standard (see Part Number Guide for more options)
Frequency Stability over Temperature	±50 ppm Standard (see Part Number Guide for more options)
Crystal Cut	AT Cut Standard
Load Capacitance	18 pF Standard (see Part Number Guide for more options)
Drive Level	1 mW Max.
Aging	±5 ppm Max. / Year Standard
Temperature	
Operating	0° C to +70° C Standard (see Part Number Guide for more options)
Storage	-40° C to +85° C Standard

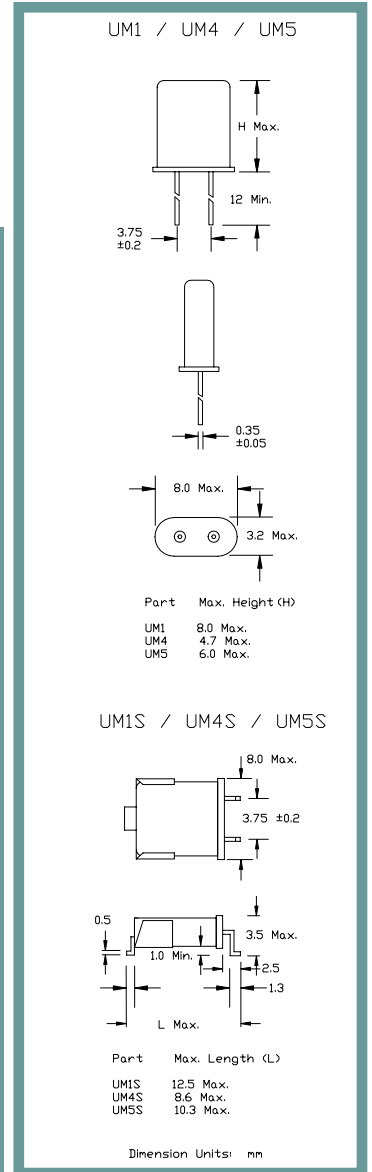

Part Number Guide		Sample Part Number: UM1 - FB1F18 - 20.000				
Package	Stability (ppm) at Room Temperature	Stability (ppm) over Operating Temperature	Operating Temperature Range	Mode (overtone)	Load Capacitance (pF)	Frequency
UM1 - (8.0 mm H) UM4 - (4.7 mm H) UM5 - (6.0 mm H)	B = ±50 ppm	B = ±50 ppm	0 = 0°C to +50°C	F = Fundamental	18 pF Standard Or Specify	- 20.000 MHz
	F = ±30 ppm	F = ±30 ppm	1 = 0°C to +70°C	3 = 3 rd overtone		
	G = ±25 ppm	G = ±25 ppm	2 = -10°C to +60°C	5 = 5 th overtone		
	H = ±20 ppm	H = ±20 ppm	3 = -20°C to +70°C			
	I = ±15 ppm	I = ±15 ppm**	5 = -40°C to +85°C			
	J = ±10 ppm*	J = ±10 ppm**	9 = -10°C to +50°C			

* Not available at all frequencies. ** Not available for all temperature ranges.



2 Lead Metal Package, 3.2 mm x 8 mm



UM1 / UM4 / UM5 Series

Pb Free Solder Reflow Profile:

Typical Circuit:

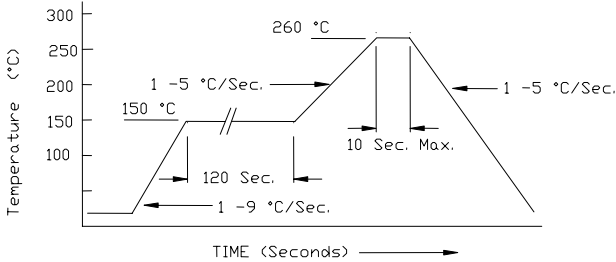

*Units are backward compatible with 240C reflow processes

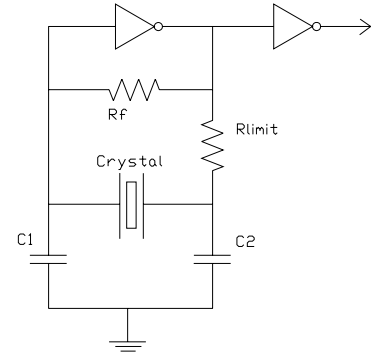

Package Information:

MSL = 1
Termination = e1 (Sn / Cu / Ag over Ni over Kovar base metal).

Environmental Specifications

Thermal Shock	MIL-STD-883, Method 1011, Condition A
Moisture Resistance	MIL-STD-883, Method 1004
Mechanical Shock	MIL-STD-883, Method 2002, Condition B
Mechanical Vibration	MIL-STD-883, Method 2007, Condition A
Resistance to Soldering Heat	J-STD-020C, Table 5-2 Pb-free devices (except 2 cycles max)
Hazardous Substance	Pb-Free / RoHS / Green Compliant
Solderability	JESD22-B102-D Method 2 (Preconditioning E)
Terminal Strength	MIL-STD-883, Method 2004, Test Condition D
Gross Leak	MIL-STD-883, Method 1014, Condition C
Fine Leak	MIL-STD-883, Method 1014, Condition A2, R1=2x10-8 atm cc/s
Solvent Resistance	MIL-STD-202, Method 215

Marking

Line 1: ILSI
Line 2: Frequency
Line 3: Date Code